

Quick Start Guide

TR3 E-Series

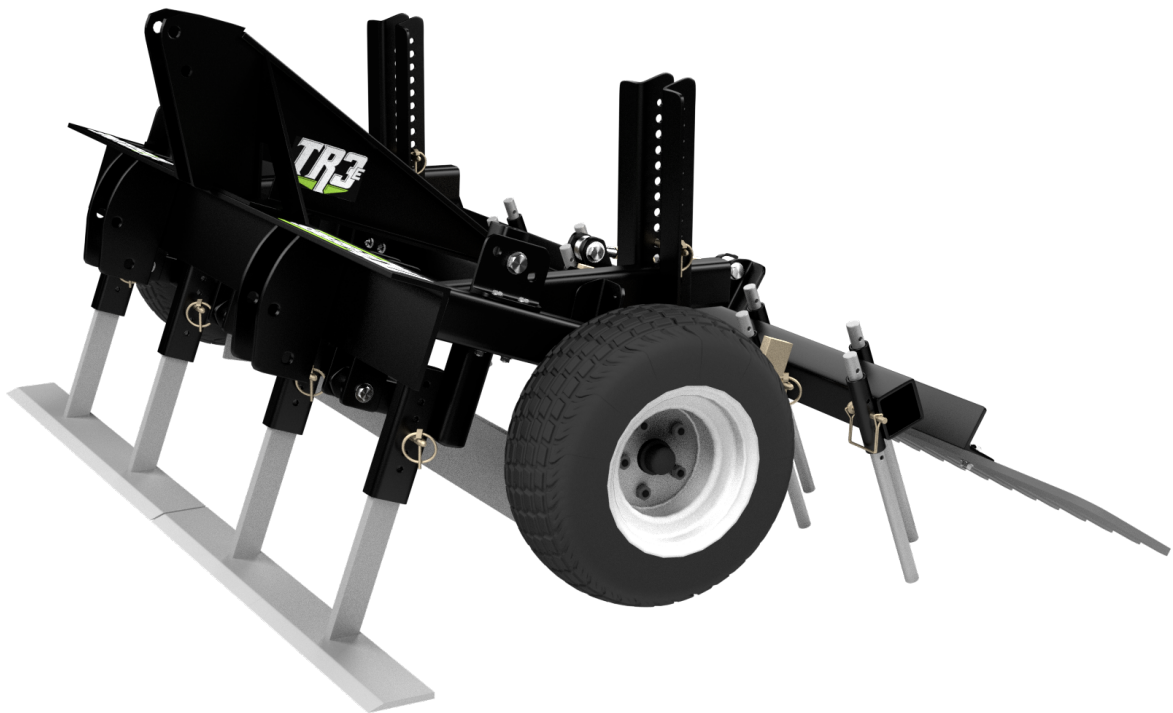

NOTE: This Quick Start Guide covers several models. Features may vary by model. Not all features in this manual are applicable to all models and the model depicted may differ from yours. The setup video for operation is available at abisupport.com under TR3 E-Series.

Welcome To The Family!

On behalf of the ABI family we would like to thank you for your recent purchase of your TR3 E-Series. Our Company's goal is to provide you, our customer; with innovative, quality tools as well as first rate customer service.

Model and Serial Number

Model Number: _____

Serial Number: _____

Invoice Number: _____

Purchaser's Name: _____

Contact Information

ABI Attachments, Inc
520 S. Byrkit Ave.
Mishawaka, IN 46544

Customer Support

Email: support@abiattachments.com
Phone: 877-788-7253
Website: www.abisupport.com

To order parts or to speak to one of ABI's Customer Service Representatives contact us Monday to Friday 9am to 5pm EST.

Note To Operator

The information presented in this manual will prepare you to operate the TR3 E-Series in a safe and knowledgeable manner. Operating the TR3 E-Series in a proper manner will provide a safer working environment and create a more efficient result. Read this manual fully and understand the entire manual prior to setup, operation, adjusting, performing maintenance, or storing TR3 E-Series. This manual contains information that will allow you the operator to get years of dependable performance from the TR3 E-Series. This manual will provide you with information on safely operating and maintaining the TR3 E-Series. Operating the TR3 E-Series outside of the stated safety and operations guidelines may result in injury to operator and equipment or void the warranty. The information provided in this manual was current at the time of printing. Variations may be present as ABI Attachments continues to improve and upgrade the TR3 E-Series for future use. ABI Attachments, Inc. reserves the right to implement engineering and design changes to the TR3 E-Series as may be necessary without prior notification.

Safety Precautions

CAUTION: Our machines are designed considering safety as the most important aspect and are the safest available in today's market. Unfortunately, human carelessness can override the safety features built into our machines. Injury prevention and work safety, aside from the features on our tools, are very much due to the responsible use of the equipment. It must always be operated prudently following with great care, the safety instructions laid out in this manual.

- Before operating equipment, read and understand the operator's manual.
- Thoroughly inspect the implement before initial operation to assure that all packaging materials, i.e., wires, bands, and tape have been removed.
- Personal protection equipment including safety glasses, safety shoes, and gloves are recommended during assembly, installation, operation, adjustment, maintaining and/or repairing the implement.
- Operate the implement only with a tractor equipped with an approved Roll-Over-Protective-System (ROPS). Always wear your seat belt. Serious injury or even death could result from falling off the tractor.
- Operate the TR3 E-Series in the daylight or under good artificial light. Operator should always be able to clearly see where they are going.
- Ensure the implement is properly mounted, adjusted and in good operating condition.
- As with all arena dragging equipment, always ensure footing material in the arena is at a consistent depth, if an arena base is installed, before engaging subsurface implements. If the footing layer depth is not consistent, you could damage your arena base layer. See page 9 for details.
- Double check implement depth into the footing to ensure it will NOT go below the footing layer into the base layer of the arena. (If base exists) This double check must be completed upon entering the arena and again after pulling forward a short distance, to remove any slack from pins and linkages, after each time the implement or linkages are adjusted.
- The TR3 E-Series may slightly settle (1/2") into footing material, after an initial pass over compacted material has been loosened, requiring adjustment to ground engaging components to prevent damage to the base layer of an arena.

Starting and Stopping

- Be sure that no one is near the machine prior to engaging or while the machine is working.
- Be sure the tractor is in neutral before starting the engine.
- After striking an obstacle, shut the tractor off, remove key and thoroughly inspect for damage before restarting.

Operation Safety

- The use of this equipment is subject to certain hazards which cannot be prevented by mechanical means or product design. All operators of this equipment must read and understand this manual, paying particular attention to safety and operating instructions, prior to using.
- Do not operate the tractor/ATV/UTV and implement when you are tired, sick, or when using medication.
- Keep all helpers and bystanders at least 50 feet away from the machine. Only properly trained people should operate this machine.
- The majority of accidents involve operators being knocked off the tractor by low hanging limbs and then being run over by the implement. Accidents are most likely to occur with machines that are loaned or rented to someone who has not read the operator's manual and is not familiar with the implement.
- Always stop the tractor, set brake, shut off the tractor engine, remove the ignition key, lower implement to the ground, and allow rotating parts to come to a complete stop before dismounting tractor. Never leave equipment unattended with the tractor running.
- Never place hands or feet under implement with tractor engine running or before you are sure all motion has stopped. Stay clear of all moving parts.
- Do not reach or place yourself under equipment until it is blocked securely.
- Do not allow riders on the implement or tractor at any time. There is no safe place for riders.
- Never place hands or feet under implement with tractor/ATV/UTV engine running or before you are sure all motion has stopped. Stay clear of all moving parts.
- Before backing up, disengage the implement from the ground and look behind carefully.
- Keep hands, feet, hair, and clothing away from moving parts.
- Never operate tractor and implement under trees with low hanging limbs. Operators can be knocked off the tractor and then run over by implement.
- Stop implement immediately upon striking an obstruction. Turn engine off, remove key, inspect and repair any damage before resuming operation.
- Stay alert for holes, rocks, and roots in the terrain and other hidden hazards. Keep away from drop-offs.
- Use extreme care and maintain minimum ground speed when transporting over a hillside, over rough ground, and when operating close to ditches or fences. Be careful when turning sharp corners.
- Reduce speed on slopes and sharp turns to minimize tipping or loss of control. Be careful when changing directions on slopes.
- Inspect the entire machine periodically. Look for loose fasteners, worn or broken parts, and leaky or loose fittings.
- Pass diagonally through sharp dips and avoid sharp drops to prevent "hanging up" tractor and implement.
- Avoid sudden starts and stops while traveling up or downhill.
- Always use down slopes; never across the face. Avoid operation on steep slopes. Slow down on sharp turns and slopes to prevent tipping and/or loss of control.

Initial Setup

CAUTION: Ensure you have 9 inches between the rear tire and the end of the lower 3-point arm.

3 Point Connection

Ensure Lower arms are stabilized to prevent excessive side movement. Slowly back up the tractor to the TR3-E while using 3-point hydraulic control to align hitch holes in lower 3-point arms with hitch pins on the implement. Secure lower arms to the implement using the hitch pins provided.

Attach the tractor to the lower arms. There are two connecting holes on the TR3-E for the bottom arms of the tractor to attach to. If the TR3-E is connected to the bottom holes, be sure to connect the top link in the bottom hole on the mast as well. Likewise, if the lower arms of the tractor are connected to the TR3 in the top hole, connect the top link using the top hole as well. The top hole is the suggested hole for operating your TR3-E. If you are regularly loading and unloading your TR3-E off of a trailer, the lower holes will give you the clearance to do this.



Each TR3-E is shipped with a complimentary 20 inch top link, but feel free to use your own. Some tractors require a smaller top link, such as what came with your tractor, or that are available for purchase at a local tractor dealer.



Sub-compact tractors: If you are using a sub-compact tractor, you may need front mounted counterweights to be able to use your ABI tool. This will ensure the front end of the tractor remains securely on the ground without loss of steering control. If a front end loader is installed on your tractor, this may minimize the need for front mounted counterweights. Additionally, you will need to adjust the speed of your 3 point hitch system so it runs as slow as possible. This will aid implement control while rough grading and help to ensure no material pile is left behind when lifting the tool as you exit the arena. Please consult your tractor owner's manual to confirm.



Before you set up your tool, confirm that the wheels are set in the standard operating position (lower hole).



Next, you will adjust the top link to level out the tool. Turn the top link to contract or extend the linkage until the upright towers of the leveling bar are vertical.



Now you can adjust the finish rake on the back of the tool. The finish rake is adjusted using the small linkage that connects to it. To achieve proper adjustment of the rake, you will adjust the linkage so you are always carrying some material on the rake, but not so much to cause material to consistently build up and plug or spill over top of the middle part of the rake. You may need to make adjustments accounting for moisture changes or vegetation growth in the material.



Components

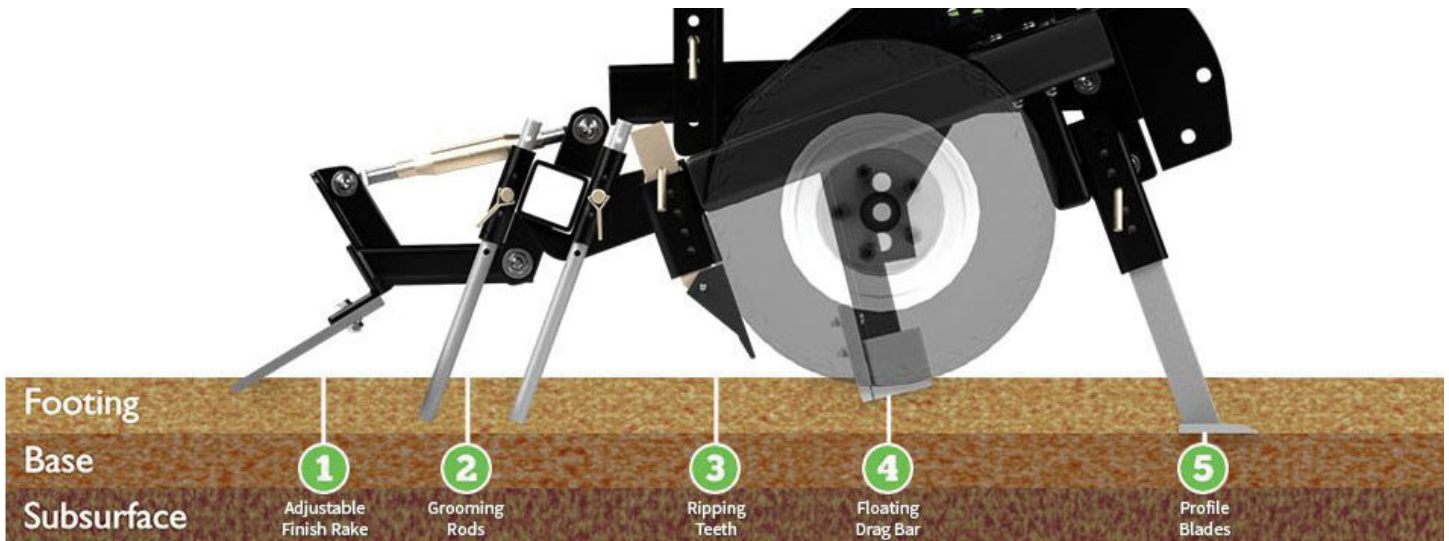

Wheels:

The wheels have three operating positions:

The bottom hole on the axle block is the standard operation position for general arena maintenance.

The center hole will lower the frame deeper into the material for more aggressive grading ideal for renovation work and can be used for arena renovation.

The top hole is for aggressive ripping. This setting will allow you to achieve the greatest amount of depth. When the wheel location is changed, you may need to make some adjustments to your leveling blade.



Scarifying Teeth:

The scarifying teeth loosen the ground to eliminate hard spots and easily penetrate compacted arena footing and gravel driveway material. They are primarily used in arena renovation and gravel driveway work to break up compaction and should be used on their own with the leveling blade and the finish rake. During daily arena maintenance, the scarifiers can be pinned up and out of play. Excess wear will be created by using them during daily grooming.

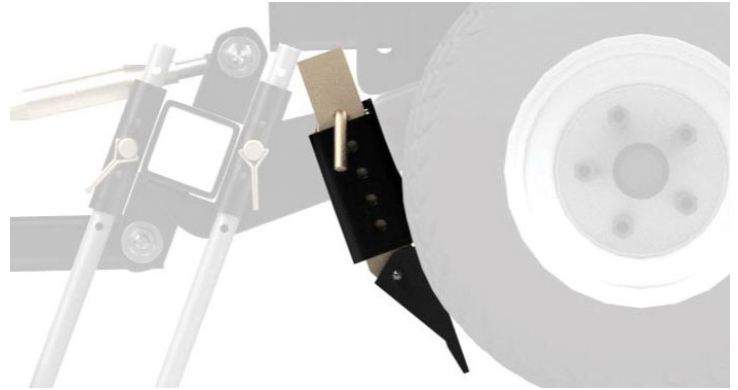

Bolt On Scarifier Tips:

The TR3-E has replaceable bolt on tips on the scarifying teeth. This feature not only ensures affordable and easy maintenance of this wear part, but also ensures peak ground penetration no matter the ground condition. If the tips wear to the point that performance is diminished, simply replace them, restoring optimal performance.



Grooming Rods:

The grooming rods are used for daily arena grooming after the original breakup of compaction by the scarifiers. The grooming rods can be adjusted by 1/2" increments to a depth of up to 6". As the grooming rods wear, they can be adjusted downward for extended life.



Profile Blades:

The profile blades can operate at a depth of up to 4" and are adjustable at ½" increments. This attachment cuts parallel to the arena grade, while riding along just above the base, to remove dangerous compaction layers and aerify the footing. This creates a sheet of material the grooming rods are then able to break up as it flows through the tool. The Profile Blade attachment ensures that what the horse and rider see on the top surface, is also what the horse feels when his hooves penetrate into the footing material. It is important to remember that the profile blades are used for grooming, not the renovation of the arena.

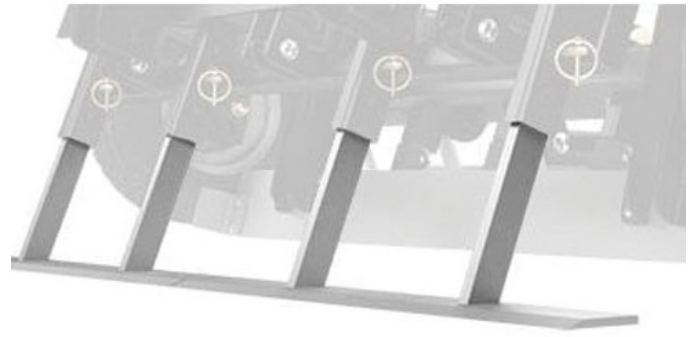

Leveling Blade:

The leveling blade can be used as an auto-leveling device when it is in the float position **Figure 1**. If the blade is carrying too much material, it can be pinned higher by inserting the pins in the upright tower underneath the handle of the leveling bar **Figure 2**. It can also be locked into place by using the adjustment pins above the bar to create a box blade on your tool **Figure 3**.

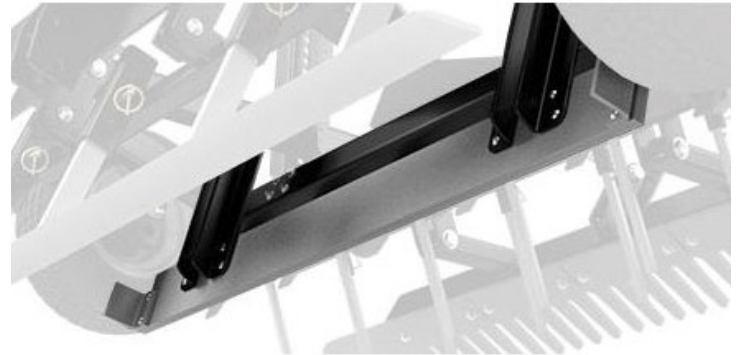

Figure 1



Figure 2



Figure 3

Finish Rake:

The finish rake breaks up clumps of material and leaves a beautiful signature finish in the arena. The finish rake is adjustable by extending or contracting the linkage at the rear of the tool.



Setting Components For Use

All of the components on your TR3-E are adjustable using the compatible pins. By removing these pins, you can adjust the components up and down within their respective pockets. The profile blades, grooming rods, scarifiers, and leveling blade all have multiple adjustment positions for fine tuned usage.

Renovation

When you set up your TR3-E it is important to identify if the arena is in need of renovation first. If you have significant highs and lows in your arena, or if it is compacted or has been neglected, you may need to renovate prior to grooming. We recommend you hire a qualified professional to renovate your arena. For the DIYers among us, please know renovation requires a different setup from everyday grooming. The main objectives when renovating are to remove vegetation, relieve compaction, and level out the arena. Please remember the arena did not get in bad condition overnight. It will take time and a lot of effort to repair it, but you now own a tool that can do the work!

In many professionally installed arenas, this “Grade” point is actually marked somewhere on the rail or wall. Perfect “grade” is a bit of a unicorn, as this is technically impossible to do without laser guided hydraulic equipment, but for most people, getting close is good enough.

If you have a professionally installed base, gently dig down with a small shovel through the hardpan footing until you reach the base material. The base is usually a different color from the footing material and is much harder. Do this in about 20 areas throughout the arena in a grid pattern. You may find the depth of the footing material changes from 1" - 5" from spot to spot in an arena needing renovation. You now need to mark these varying depths, either with flags or a can of white spray paint; your choice. Either insert the number of flags equal to the depth of the footing at each hole you dug (3 inches = 3 flags), or spray paint the depth of the footing material beside each hole. When you measure the hole, measure the “struck” depth, meaning level off the footing around the hole to match the material around it. Don’t measure footing mounded around the hole. Now take a good look at the arena and try to find other areas that may look higher or lower. Dig and mark these areas as well. Now you will have a good idea of the depth of the footing throughout the arena. It may be helpful to take a number of photos of the footing depth for reference during the grading process for after you pull your flags or cover your markings.

Vegetation

Techniques used to eliminate vegetation from the arena will vary based on how established the root system has become. For light recent vegetation, normal dragging should eliminate the growth. To eliminate mature vegetation from the arena, if it is environmentally responsible to do so, spray Roundup to kill the vegetation. Allow the arena to sit until the vegetation dies (could be many days). Next, mow the vegetation as short as you are able and use a blower and/or rake to remove the cut excess vegetation. Now use the TR3 E-Series profile blades about an inch into the arena footing to slice the vegetation root system (like a sod cutter). Do this when the arena is VERY dry. You will need to ensure that ALL other ground engaging components are positioned up and out of play, otherwise they will plug up with vegetation and begin to plow. Now that the vegetation is loose, it is time to collect it into spoils piles for removal from the arena. Use the rear finish rake and leveling bar to collect vegetation into spoils piles. The TR3 E-Series finish rake can be used to slowly push vegetation backward into the piles. Remove the piles and dispose of the vegetation with a front end loader or by wheelbarrow from the arena.

The next step is to use the leveling component of your drag and begin to pull or cut the high areas of the arena footing and fill in the low areas. You do NOT just drag around the area to accomplish this, that will make the problem worse. You will need to engage the leveling component only on the high areas (cut) and raise the 3-point once you get that material you are pulling to the low areas (fill). Move the high areas (cut) into the low areas (fill). This is called cut and fill grading. Next, you simply repeat the process over and over again. You may need to use ripping teeth to loosen the hard pan in the high areas. Just be careful not to rip into the base. Start with shallow ripping and never rip into your low areas. Only allow the drag to be in contact with the ground on the high areas. Raise the drag over low areas. Repeat and continue to measure your footing depth until you’ve achieved uniformity of depth throughout the arena. Gauge wheels only protect the base if you have a consistent footing depth throughout the arena.

Leveling & Loosening Arena Footing

Leveling & Loosening Arena Footing: The first thing you need to do is determine what the "grade" of the arena is. “Grade” is the high point your arena footing material could reach on your rail or wall, if all the footing material was evenly distributed consistently throughout the arena.

If you want to save time, you may consider renting or purchasing a laser transmitter on a tripod and a grade stick with a laser receiver/detector. With this equipment, you may have one person walk the arena with a grade stick (w/ laser detector) to determine how high or low the footing material is in a given spot based on the laser transmitter beam. This person can then give the tractor operator instruction as to how much material to cut from high areas and fill into low areas. There are MANY factors at play when working with lasers that require a skilled professional.

Arenas that do not have a professionally installed base will have natural undulations that rise and fall with the terrain. For these arenas, plotting a grid or using a laser may be overkill. Instead, work to normalize the high and low areas the best you can. Start by identifying the high and low areas in your arena. Once the highs and lows are identified, mark your high areas using spray paint with an “O” and low areas with an “X”; as shown on the next page.



Next you will adjust the scarifying teeth for use. You will use the scarifying teeth to rip and relieve compaction in the high areas. Just a reminder, always be mindful to not loosen your low areas as you may begin to dig into the natural materials under the sand you brought in as a footing layer.

Next you will adjust the scarifying teeth for use. You will use the scarifying teeth to rip and relieve compaction in the high areas. Just a reminder, always be mindful to not loosen your low areas as you may begin to dig into the natural materials under the sand you brought in as a footing layer.

Grooming

Techniques used to eliminate vegetation from the arena will vary based on how established the root system has become. For light recent vegetation, normal dragging should eliminate the growth. To eliminate mature vegetation from the arena, if it is environmentally responsible to do so, spray Roundup to kill the vegetation. Allow the arena to sit until the vegetation dies (could be many days). Next, mow the vegetation as short as you are able and use a blower and/or rake to remove the cut excess vegetation. Now use the TR3 E-Series profile blades about an inch into the arena footing to slice the vegetation root system (like a sod cutter). Do this when the arena is VERY dry. You will need to ensure that ALL other ground engaging components are positioned up and out of play, otherwise they will plug up with vegetation and begin to plow. Now that the vegetation is loose, it is time to collect it into spoils piles for removal from the arena. Use the rear finish rake and leveling bar to collect vegetation into spoils piles. The TR3 E-Series finish rake can be used to slowly push vegetation backward into the piles. Remove the piles and dispose of the vegetation with a front end loader or by wheelbarrow from the arena.



Maintenance

Wheels and Hubs

The bearings in the hubs on the TR3-E should be greased every 3 months. They should also be greased before any long period of storage.

Top Link

Be sure to keep the threaded bolts on your top link greased so they do not seize over time.

Finish Rake

Occasionally over the life of your tool, you may have a bent finger on the finish rake. If this occurs, you can place a pipe over the bent finger and use the pipe to straighten the finger back out.

Grooming Rods

If you discover one of the grooming rods appears to be bent, you can use a vice and hammer to bend it back straight.

Finish

If you start to see scratches on the tool, you can use a rust stopping primer and paint to refinish the damaged area.

Scarifier Tips and Shanks Guide

The tip on the left is worn and the tip on the right is new. The white line shows the maximum wear point before there is damage to the shank. Going much higher than the white line will mean that the shank will need to be replaced.



Pictured here is a close up of the phone number on the side. If you hit the phone number, the tips should be replaced as soon as possible.

All of your ground engaging components are considered wear parts and will need to be replaced as they wear out from use. You can refer to the scarifier tip guide on the following page to gauge wear on your scarifying components. To reorder, please contact the ABI Support department at 855.211.0598.

The tip bolted on a standard 9” shank.



The shank is held on to the TR3 E-Series by a bent pin (#1) and a lynch pin (#2).

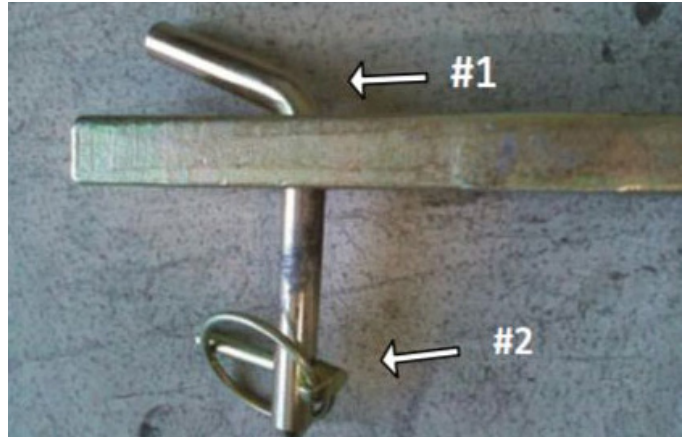

Troubleshooting/FAQ

- **My profile blades are making a chattering noise as I drag.**
 - This is probably due to the profile blades not being level. This can cause them to chatter or create waves in the arena. To resolve this issue, double check to make sure the upright towers are vertically level when engaged in your material.
- **One of my tires is locked up or wobbling.**
 - Remove the hub from spindle and check the bearings. In most cases, tires lock up due to the bearings not being greased, leading to bearing failure.
- **My arena footing is too fluffy.**
 - Take the grooming rods out of play. You can then pin above and below the leveling blade, locking it in place. This will create a compacting effect with the now fixed blade. The finish rake also has a compacting effect and can be adjusted to carry more material, thereby re-firming your footing.
- **Tractor is bogging down.**
 - First check how much material is on leveling blade. If you see material flowing over the blade, then you can pin the blade up a hole or two, allowing more material to pass under the blade.
 - Check the depth of grooming rods and scarifier tips. The deeper you're attempting to rip, the more tension you're putting on the tractor and the more likely the tractor is going to bog down.
- **Trouble steering.**
 - If your tractor is not following your front tires or you're lacking front-end traction, you might need to add front end weights. Check the weight requirements in your tractor's owner's manual.

Contact Information

ABI Attachments, Inc
520 S. Byrkit Ave.
Mishawaka, IN 46544

Customer Support

Email: support@abiattachments.com
Phone: 877-788-7253
Website: www.abisupport.com

To order parts or to speak to one of ABI's Customer Service Representatives contact us Monday to Friday 9am to 5pm EST.

The setup video for operation is available at abisupport.com under TR3 E-Series or by following this link: <https://www.youtube.com/watch?v=Fk3AJaPJNMY&feature=youtu.be>

For additional information on the use or setup of the TR3 E-Series, please contact the ABI customer support team at 855.211.0598.

Additional support videos are available at the ABI support page (abisupport.com) under each tool.

Warranty Information and Return Policy - Warranty and return policy information can also be found on the ABI support page under each tool. For additional questions regarding warranty or return policy, contact the ABI customer support team at 855.211.0598.

